

# ProfiEVO

PROFESSIONAL MANUAL TILE CUTTER

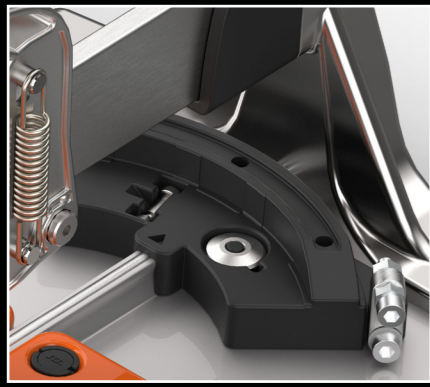

**EXTRA SPARE WHEEL**  
One more extra set spare wheel included. You never run out.



**SIDE EXTENSIONS**  
A new design of the lateral supports ensures great stability when cutting large formats. Particularly long in extension make the cut comfortable and safe.



**TRANSPORT**  
Very easy to carriage with all the parts closed, to reduce the encumbrance.



	Art. 61600EV	Art. 61300EV	Art. 61000EV	Art. 6850EV	Art. 6601EV	Art. 6401EV
CUTTING LENGTH	1630 mm	1330 mm	1030 mm	880 mm	630 mm	450 mm
MAX SIZE TILE FOR DIAGONAL CUTS	1150x1150 mm	940x940 mm	720x720 mm	620x620 mm	440x440 mm	320x320 mm
CUTTING THICKNESS	5 - 15 mm					
CUTTING WHEEL	Ø 15 x 6 x 1,5 mm					
PACKING DIMENSION	1996x285x265 mm	1696x285x265 mm	1396x285x265 mm	1246x285x265 mm	996x285x265 mm	816x285x265 mm
PIECES ON PALLET	14		21		28	
PALLET DIMENSION	720x1990x2080 mm	720x1750x2080 mm	880x1400x2080 mm	880x1200x2080 mm	1000x1200x2080 mm	820x1200x2080 mm
NET WEIGHT	19,9 Kg	17,0Kg	14,1 Kg	13 Kg	9,5 Kg	8,5 Kg



AUTHORIZED DEALER:



Z. i. 2 - Via Cavatorta, 6/1 | 48033 Cotignola (Ra) | ITALY  
www.battipav.com | sales@battipav.com



June 2020

**BATTIPAV**™

MACCHINE PER EDILIZIA | MACHINES FOR BUILDING



### ALUMINIUM MAGNETIC FOOT

The breaking foot in aluminum with a white rubber protection to avoid scratches. A magnet placed on the foot allows, by lifting it, to make the whole incision with a single move. Then, by lifting the handle, the foot is immediately ready for separation. Speed and precision: 1 second operation!



### CARRIAGE

The carriage in aluminium is equipped with two ball-bearings one on the top and one on the bottom of the rail for a perfect sliding and top precision.

**STRUCTURE**  
Strong body made in aluminium draw-plate to get rigidity and lightness at the same time.

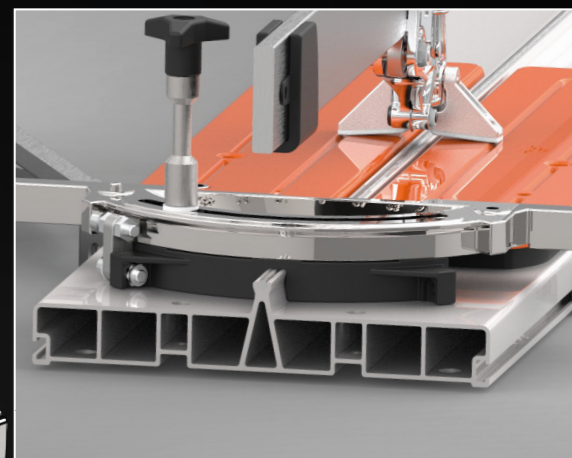

### PUSHING CUTTING SYSTEM

# 100% ALUMINIUM

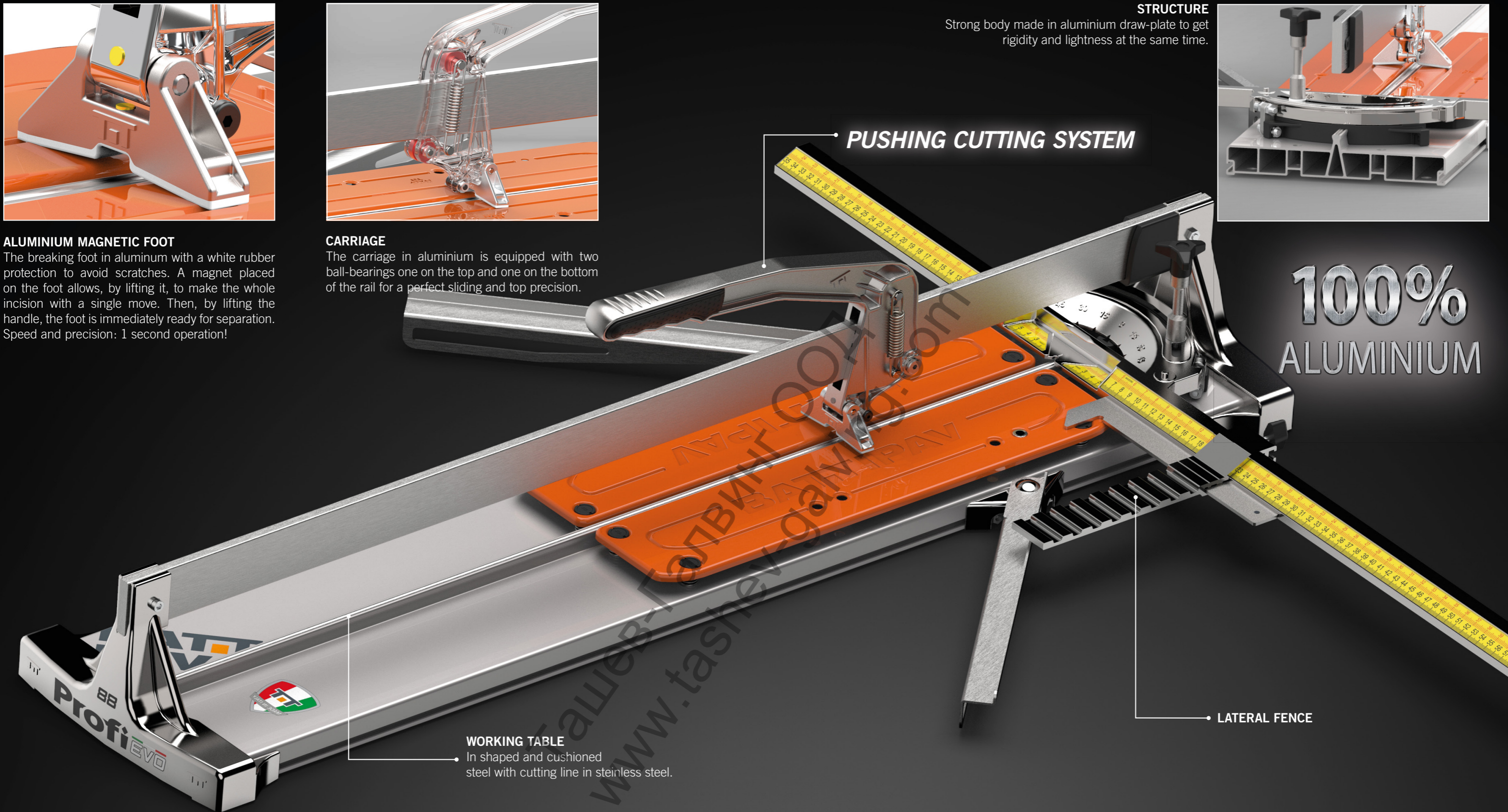

### WORKING TABLE

In shaped and cushioned steel with cutting line in stainless steel.

### LATERAL FENCE

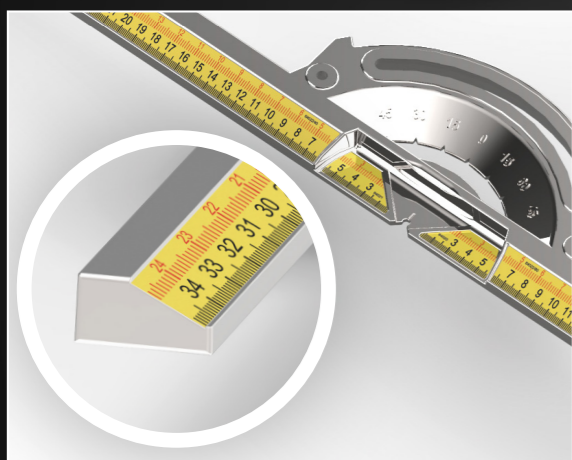

### GONIOMETRIC SQUARE

The goniometric square is a monobloc, very rigid and stable, a lectern shape on which the centimeter scale is positioned; so you have a direct reading of the measurement to be cut.

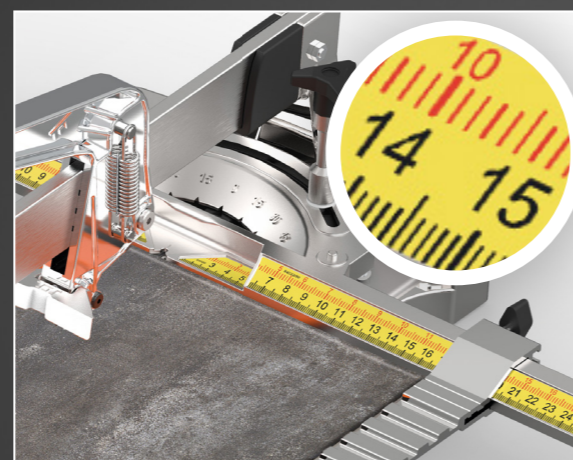

### QUICK READING

The new designed goniometric square allows a perfect reading of the measurement for straight cut (black lower scale) as well as diagonal cut (red upper scale).

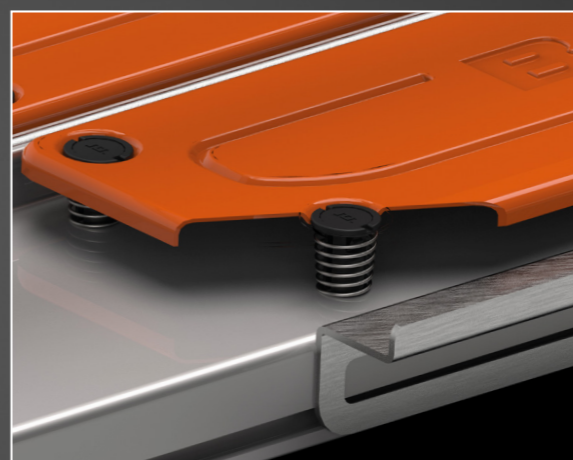

### WORKTOPS

The worktops have been updated: special springs (4 x each side) guarantee rapid separation of the cut part and an excellent finish result